

Linear actuator Vario

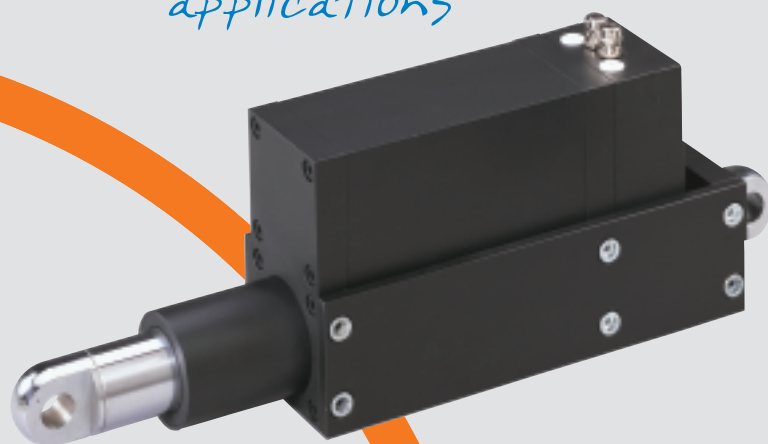

*Our most powerful model
for heavy-duty
applications*



Linear actuators Vario 1 and 2



Description · Applications · Options

The linear actuators of the Vario series have the following outstanding features:

- Combination of high performance and low space requirement
- Robust construction
- High static load capacity
- Flexible concept thanks to a versatile modular system
- Minimum maintenance required
- Optimum protection against dirt, dust and other environmental influences
- Precise positioning thanks to electronic switches for two end positions and one intermediate position; optional output of a stroke-dependent analogue signal

Applications

- Special machine construction
- Materials handling technology
- Overhead catenary construction
- Shipbuilding
- Communications engineering

The facts

	Vario 1	Vario 2
Load (kN)	50	100
Stroke speed (mm/s)	1-70	
Stroke length (mm)	max. 800	max. 1000
Operating voltage	400 V/3 AC, 50 Hz	400 V/3 AC, 50 Hz
Control voltage electronic limit switches	24 V DC or 230 V AC	
Voltage supply analogue output	24 V DC / 20 mA	
Temperature range (°C)	-10 to +50	
Protection type	IP 54	
Piston rod	torsion-lock	
Double scraper ring	at piston outlet	
Housing	black coating	
Cable length (m)	1.5	

Options

- Brake
- Analogue output for a stroke-dependent tension signal (0...10V)
- Encoder
- DIN 71752 clevis end
- DIN 648 swivel eye
- Threaded bolt M20x38

Other stroke lengths, special voltages, circuit variants, cable types, special coatings as well as additional equipment (protective sleeve, plug connections, etc.) on request.

Our most powerful models

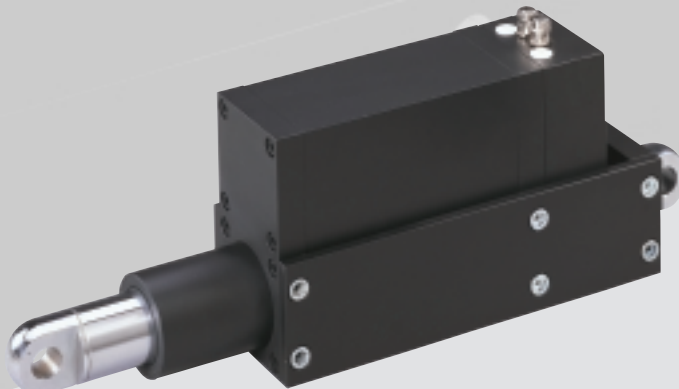

Vario 1

Load (N) and stroke speeds (mm/s)

Version	400 V-3 AC Rating: S3 15% Pushing/ pulling force (kN)	Stroke speed (mm/s)	Spindle dimensions	Prescribed brake	Current consumption (A)	Power (VA)
A	10	70	KGT 32x10	yes	3	2100
B	15	50	KGT 32x10	yes	3	2100
C	4	50	Tr 40x7	yes	3	2100
D	8	30	Tr 40x7	yes	3	2100
E	15	20	Tr 40x7	yes	3	2100
F	30	10	Tr 40x7	no	3	2100
G	40	6	Tr 40x7	no	3	2100
H	50	3	Tr 40x7	no	1.7	1200
I	40	1	Tr 40x7	no	1.7	1200

All technical data represent average values and are based on an ambient temperature of 20°C.

Mounting types Vario 1

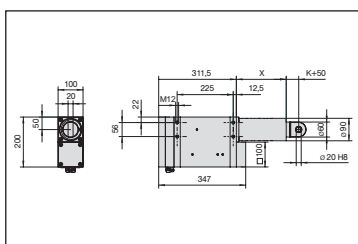

Threaded holes / Lug

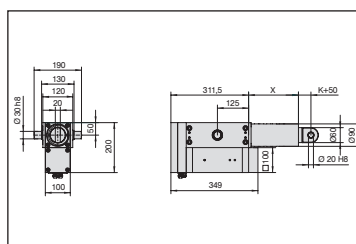

Pivot / Lug

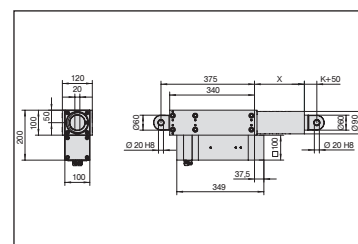

Lug / Lug

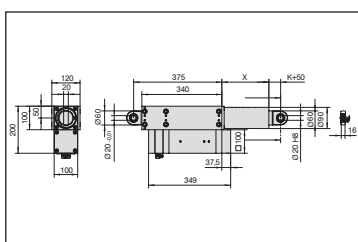

Swivel eye / Swivel eye

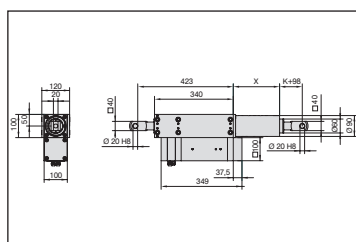

Clevis end / Clevis end

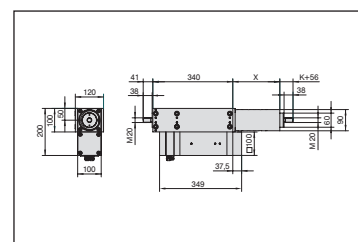

Threaded bolt / Threaded bolt

Options Vario 1

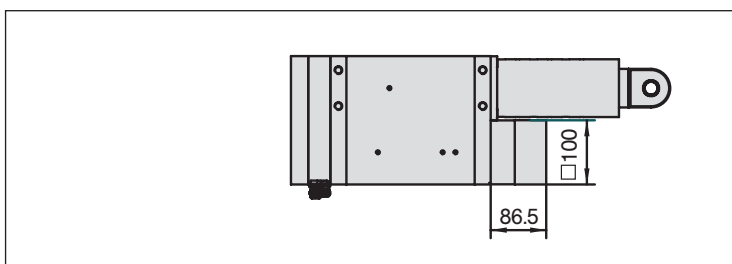

Version with brake

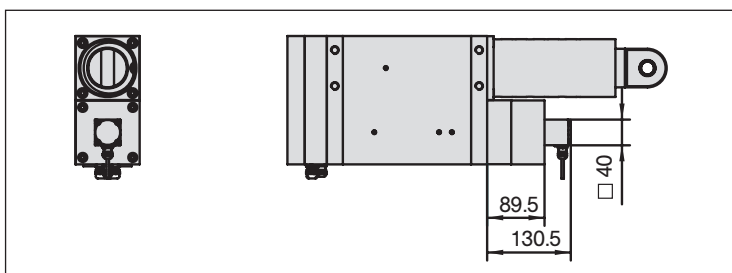

Version with brake and encoder

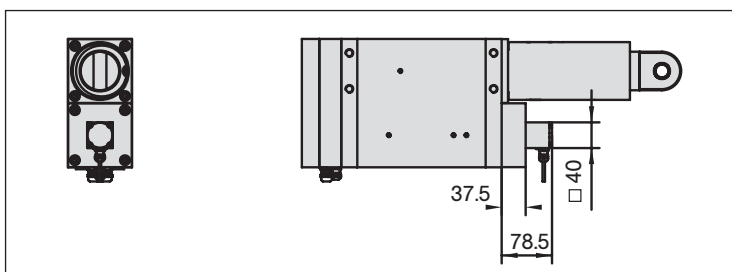

Version with encoder

Stroke length (mm)	200	400	600	800
Dimension X (mm)	200	400	650	850

Version	A	B	C	D	E	F	G	H	I
Dimension K (mm)	15	15	0	0	0	0	0	0	0

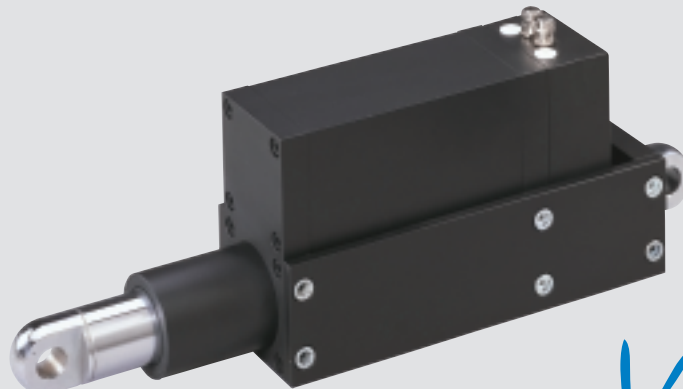

Vario 2

Load (N) and stroke speeds (mm/s)

Version	400 V-3 AC Rating: S3 15% Pushing/ pulling force (kN)	Stroke speed (mm/s)	Spindle dimensions	Prescribed brake	Current consumption (A)	Power (VA)
A	20	70	KGT 40x10	yes	6	4160
B	45	35	KGT 40x10	yes	6	4160
C	10	55	Tr 50x8	yes	6	4160
D	16	30	Tr 50x8	yes	6	4160
E	30	20	Tr 50x8	yes	6	4160
F	60	10	Tr 50x8	yes	6	4160
G	100	5	Tr 50x8	yes	6	4160
H	100	2	Tr 50x8	yes	3	2080
I	100	1	Tr 50x8	yes	2.5	1730

All technical data represent average values and are based on an ambient temperature of 20°C.

Mounting types Vario 2

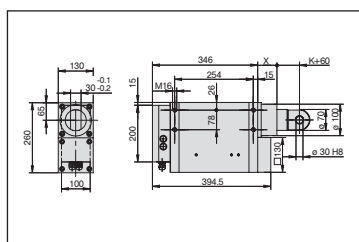

Threaded holes / Lug

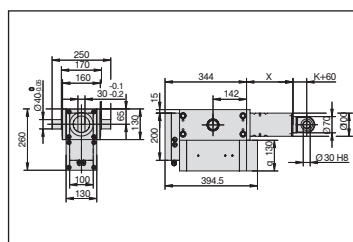

Pivot / Lug

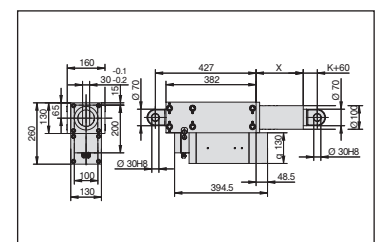

Lug / Lug

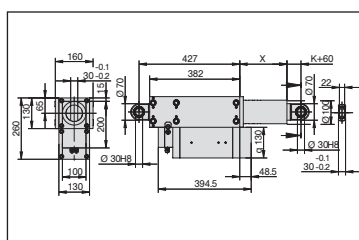

Swivel eye / Swivel eye

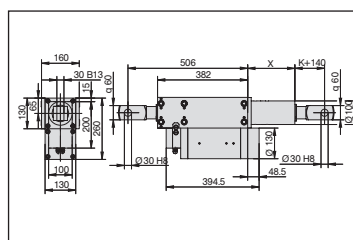

Clevis end / Clevis end

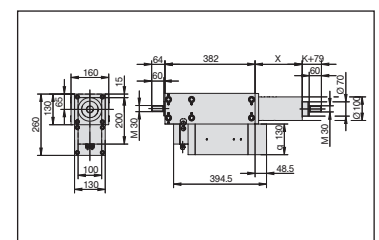

Threaded bolt / Threaded bolt

Vario 2

Options Vario 2

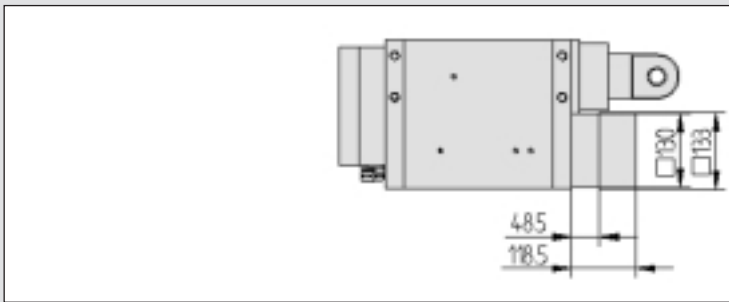

Version with brake

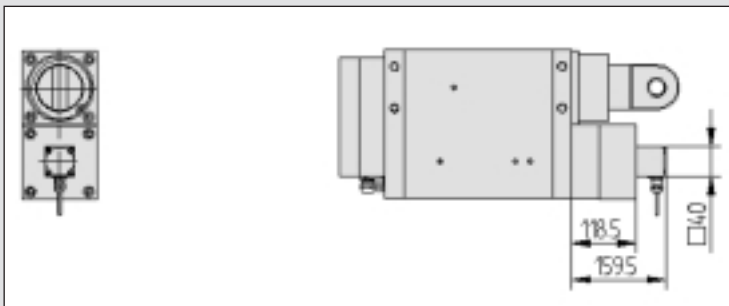

Version with brake and encoder

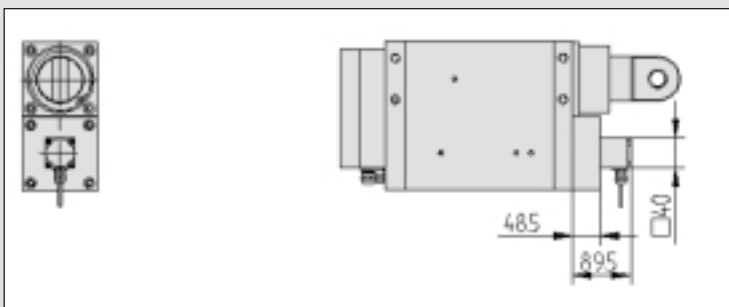

Version with encoder

Stroke length (mm)	200	400	600	800
Dimension X (mm)	200	400	700	900

Version	A	B	C	D	E	F	G	H	I
Dimension K (mm)	15	15	0	0	0	0	0	0	0

elero GmbH

Linearantriebstechnik

Nassaeckerstrasse 11

D-07381 Poesneck

Phone +49 (0) 3647 / 46 07-0

Fax Reception +49 (0) 3647 / 46 07-40

Fax Purchasing department -41

Fax Sales department -42

Head office:

Linsenhofer Str. 59-63

D-72660 Beuren

Phone +49 (0) 70 25 / 13-02

Fax Reception +49 (0) 70 25 / 13-212

info@elero-linear.de

www.elero-linear.com